



# Self-Calibrating, 16-Bit ANALOG-TO-DIGITAL CONVERTER

## FEATURES

- COMPLETE DATA ACQUISITION SYSTEM IN A TINY SOT23-6 PACKAGE
- 16-BITS NO MISSING CODES
- INL: 0.0125% of FSR MAX
- CONTINUOUS SELF-CALIBRATION
- SINGLE-CYCLE CONVERSION
- PROGRAMMABLE GAIN AMPLIFIER  
GAIN = 1, 2, 4, OR 8
- LOW NOISE: 4 $\mu$ Vp-p
- PROGRAMMABLE DATA RATE: 8SPS to 128SPS
- INTERNAL SYSTEM CLOCK
- I<sup>2</sup>C™ INTERFACE
- POWER SUPPLY: 2.7V to 5.5V
- LOW CURRENT CONSUMPTION: 90 $\mu$ A
- AVAILABLE IN EIGHT DIFFERENT ADDRESSES

## APPLICATIONS

- PORTABLE INSTRUMENTATION
- INDUSTRIAL PROCESS CONTROL
- SMART TRANSMITTERS
- CONSUMER GOODS
- FACTORY AUTOMATION
- TEMPERATURE MEASUREMENT

I<sup>2</sup>C is a registered trademark of Philips Incorporated.

## DESCRIPTION

The ADS1100 is a precision, continuously self-calibrating Analog-to-Digital (A/D) converter with differential inputs and up to 16 bits of resolution in a small SOT23-6 package. Conversions are performed ratiometrically, using the power supply as the reference voltage. The ADS1100 uses an I<sup>2</sup>C-compatible serial interface and operates from a single power supply ranging from 2.7V to 5.5V.

The ADS1100 can perform conversions at rates of 8, 16, 32, or 128 samples per second. The onboard Programmable Gain Amplifier (PGA), which offers gains of up to 8, allows smaller signals to be measured with high resolution. In single-conversion mode, the ADS1100 automatically powers down after a conversion, greatly reducing current consumption during idle periods.

The ADS1100 is designed for applications requiring high-resolution measurement, where space and power consumption are major considerations. Typical applications include portable instrumentation, industrial process control, and smart transmitters.

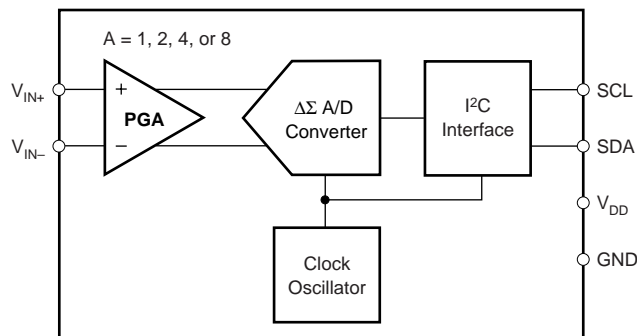

Please be aware that an important notice concerning availability, standard warranty, and use in critical applications of Texas Instruments semiconductor products and disclaimers thereto appears at the end of this data sheet.

All trademarks are the property of their respective owners.

PRODUCTION DATA information is current as of publication date. Products conform to specifications per the terms of Texas Instruments standard warranty. Production processing does not necessarily include testing of all parameters.

## ABSOLUTE MAXIMUM RATINGS

$V_{DD}$ to GND .....	-0.3V to +6V
Input Current .....	100mA, Momentary
Input Current .....	10mA, Continuous
Voltage to GND, $V_{IN+}$ , $V_{IN-}$ .....	-0.3V to $V_{DD} + 0.3V$
Voltage to GND, SDA, SCL .....	-0.5V to 6V
Maximum Junction Temperature .....	+150°C
Operating Temperature .....	-40°C to +125°C
Storage Temperature .....	-60°C to +150°C
Lead Temperature (soldering, 10s) .....	+300°C

NOTE: (1) Stresses above those listed under "Absolute Maximum Ratings" may cause permanent damage to the device. Exposure to absolute maximum conditions for extended periods may affect device reliability.



## ELECTROSTATIC DISCHARGE SENSITIVITY

This integrated circuit can be damaged by ESD. Texas Instruments recommends that all integrated circuits be handled with appropriate precautions. Failure to observe proper handling and installation procedures can cause damage.

ESD damage can range from subtle performance degradation to complete device failure. Precision integrated circuits may be more susceptible to damage because very small parametric changes could cause the device not to meet its published specifications.

## PACKAGE/ORDERING INFORMATION

PRODUCT	I <sup>2</sup> C ADDRESS	PACKAGE-LEAD	PACKAGE DESIGNATOR <sup>(1)</sup>	SPECIFIED TEMPERATURE RANGE	PACKAGE MARKING	ORDERING NUMBER	TRANSPORT MEDIA, QUANTITY
ADS1100	1001 000	SOT23-6	DBV	-40°C to +85°C	AD0	ADS1100A0IDBVT	Tape and Reel, 250
"	"	"	"	"	"	ADS1100A0IDBVR	Tape and Reel, 3000
ADS1100	1001 001	SOT23-6	DBV	-40°C to +85°C	AD1	ADS1100A1IDBVT	Tape and Reel, 250
"	"	"	"	"	"	ADS1100A1IDBVR	Tape and Reel, 3000
ADS1100	1001 010	SOT23-6	DBV	-40°C to +85°C	AD2	ADS1100A2IDBVT	Tape and Reel, 250
"	"	"	"	"	"	ADS1100A2IDBVR	Tape and Reel, 3000
ADS1100	1001 011	SOT23-6	DBV	-40°C to +85°C	AD3	ADS1100A3IDBVT	Tape and Reel, 250
"	"	"	"	"	"	ADS1100A3IDBVR	Tape and Reel, 3000
ADS1100	1001 100	SOT23-6	DBV	-40°C to +85°C	AD4	ADS1100A4IDBVT	Tape and Reel, 250
"	"	"	"	"	"	ADS1100A4IDBVR	Tape and Reel, 3000
ADS1100	1001 101	SOT23-6	DBV	-40°C to +85°C	AD5	ADS1100A5IDBVT	Tape and Reel, 250
"	"	"	"	"	"	ADS1100A5IDBVR	Tape and Reel, 3000
ADS1100	1001 110	SOT23-6	DBV	-40°C to +85°C	AD6	ADS1100A6IDBVT	Tape and Reel, 250
"	"	"	"	"	"	ADS1100A6IDBVR	Tape and Reel, 3000
ADS1100	1001 111	SOT23-6	DBV	-40°C to +85°C	AD7	ADS1100A7IDBVT	Tape and Reel, 250
"	"	"	"	"	"	ADS1100A7IDBVR	Tape and Reel, 3000

NOTE: (1) For the most current specifications and package information, refer to our web site at [www.ti.com](http://www.ti.com).

## PIN CONFIGURATION

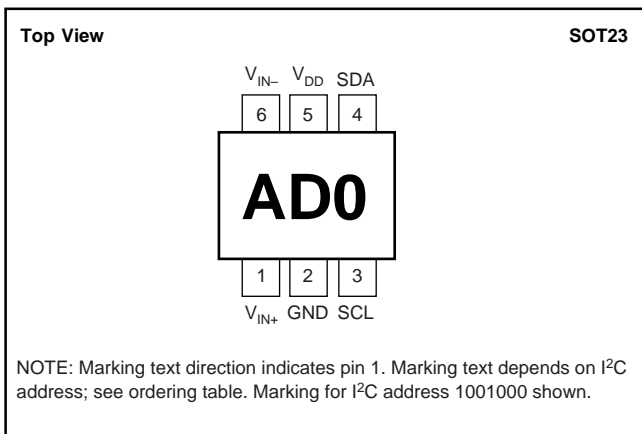

# ELECTRICAL CHARACTERISTICS

All specifications at  $-40^{\circ}\text{C}$  to  $+85^{\circ}\text{C}$ ,  $V_{\text{DD}} = 5\text{V}$ ,  $\text{GND} = 0\text{V}$ , and all PGAs, unless otherwise noted.

PARAMETER	CONDITIONS	ADS1100			UNITS
		MIN	TYP	MAX	
<b>ANALOG INPUT</b> Full-Scale Input Voltage Analog Input Voltage Differential Input Impedance Common-Mode Input Impedance	$(V_{\text{IN}+} - V_{\text{IN}-})$ $V_{\text{IN}+}, V_{\text{IN}-}$ to GND	GND - 0.2	$\pm V_{\text{DD}}/\text{PGA}$ 2.4/PGA 8	$V_{\text{DD}} + 0.2$	V V M $\Omega$ M $\Omega$
<b>SYSTEM PERFORMANCE</b> Resolution and No Missing Codes  Conversion Rate  Output Noise Integral Nonlinearity Offset Error Offset Drift  Gain Error Gain Error Drift Common-Mode Rejection	DR = 00 DR = 01 DR = 10 DR = 11  DR = 00 DR = 01 DR = 10 DR = 11  See Typical Characteristic Curves DR = 11, PGA = 1, End Point Fit <sup>(1)</sup>  PGA = 1 PGA = 2 PGA = 4 PGA = 8  At DC, PGA = 8 At DC, PGA = 1	12 14 15 16  104 26 13 6.5        94	128 32 16 8  128 32 16 8  $\pm 0.003$ $\pm 2.5/\text{PGA}$ 1.5 1.0 0.7 0.6 0.01 2 100 85	12 14 15 16  184 46 23 11.5  $\pm 0.0125$ $\pm 5/\text{PGA}$ 8 4 2 2 0.1	Bits Bits Bits Bits  SPS SPS SPS SPS  % of FSR <sup>(2)</sup> mV $\mu\text{V}/^{\circ}\text{C}$ $\mu\text{V}/^{\circ}\text{C}$ $\mu\text{V}/^{\circ}\text{C}$ $\mu\text{V}/^{\circ}\text{C}$ % ppm/ $^{\circ}\text{C}$ dB dB
<b>DIGITAL INPUT/OUTPUT</b> Logic Level $V_{\text{IH}}$ $V_{\text{IL}}$ $V_{\text{OL}}$ Input Leakage $I_{\text{IH}}$ $I_{\text{IL}}$	$I_{\text{OL}} = 3\text{mA}$  $V_{\text{IH}} = 5.5\text{V}$ $V_{\text{IL}} = \text{GND}$	$0.7 \cdot V_{\text{DD}}$ GND - 0.5 GND  -10		6 $0.3 \cdot V_{\text{DD}}$ 0.4  10	V V V  $\mu\text{A}$ $\mu\text{A}$
<b>POWER-SUPPLY REQUIREMENTS</b> Power-Supply Voltage Supply Current  Power Dissipation	$V_{\text{DD}}$ Power Down Active Mode  $V_{\text{DD}} = 5.0\text{V}$ $V_{\text{DD}} = 3.0\text{V}$	2.7	0.05 90  450 210	5.5 2 150  750	V $\mu\text{A}$ $\mu\text{A}$  $\mu\text{W}$ $\mu\text{W}$

NOTES: (1) 99% of full-scale. (2) FSR = Full-Scale Range =  $2 \cdot V_{\text{DD}}/\text{PGA}$ .

# TYPICAL CHARACTERISTICS

At  $T_A = 25^\circ\text{C}$  and  $V_{DD} = 5\text{V}$ , unless otherwise noted.

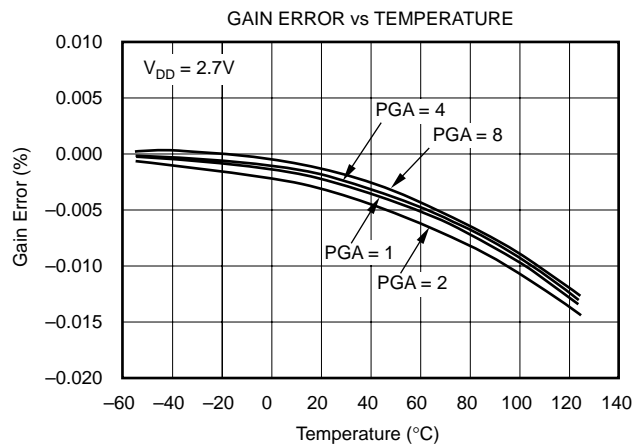
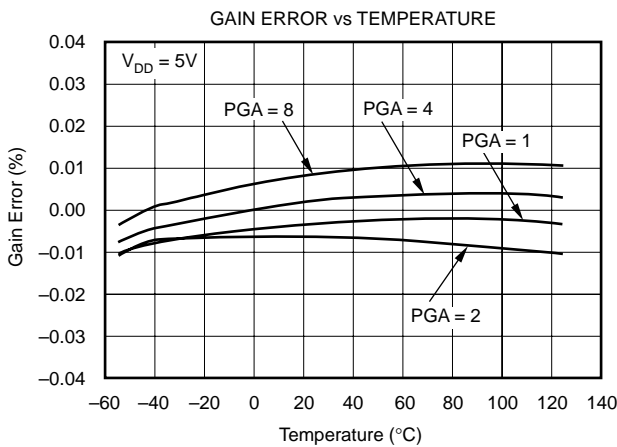
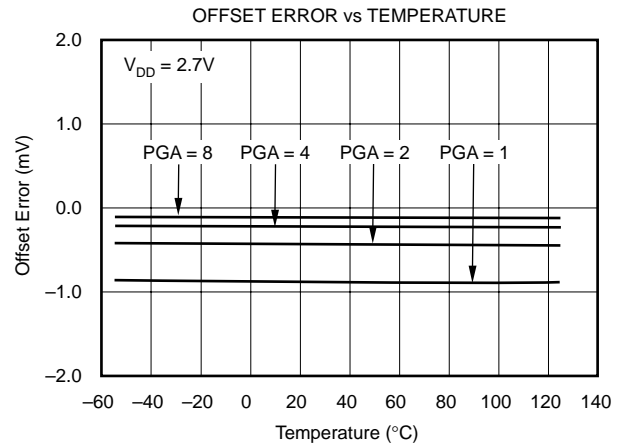
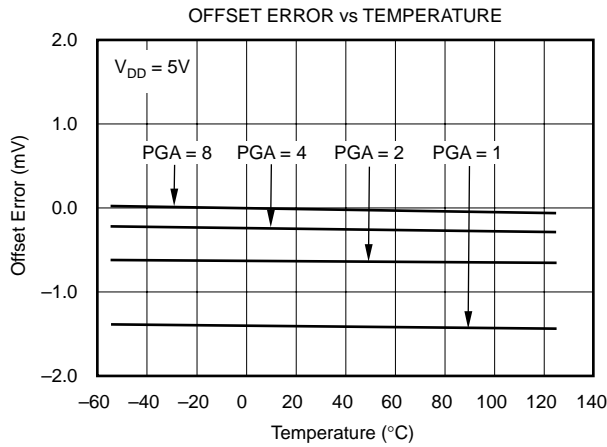
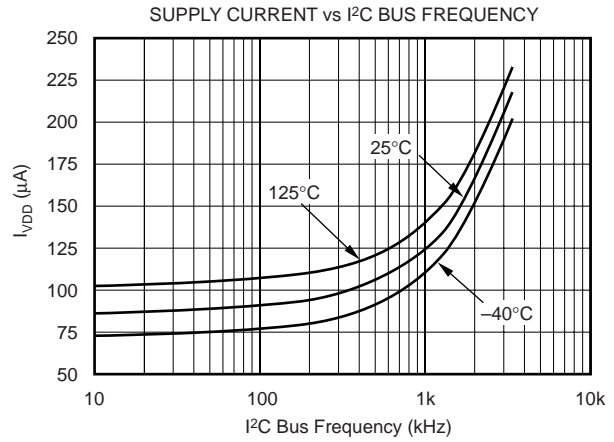
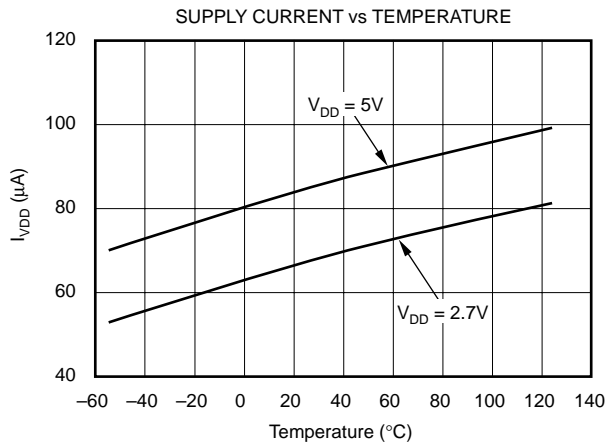

# TYPICAL CHARACTERISTICS (Cont.)

At  $T_A = 25^\circ\text{C}$  and  $V_{DD} = 5\text{V}$ , unless otherwise noted.

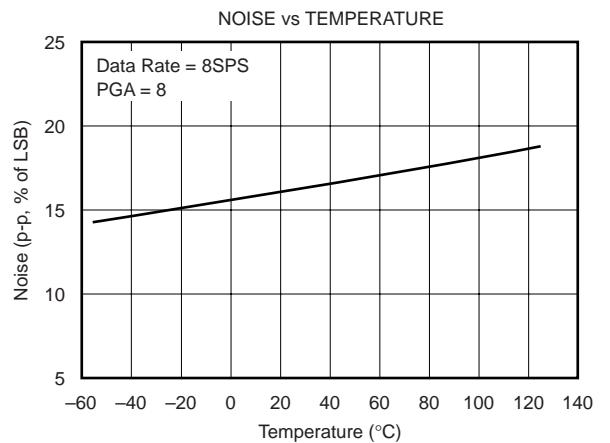
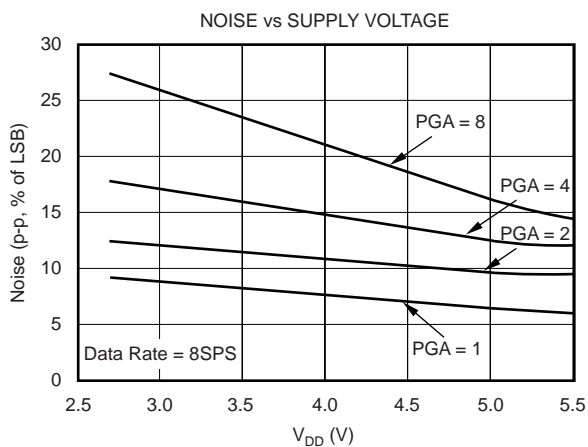
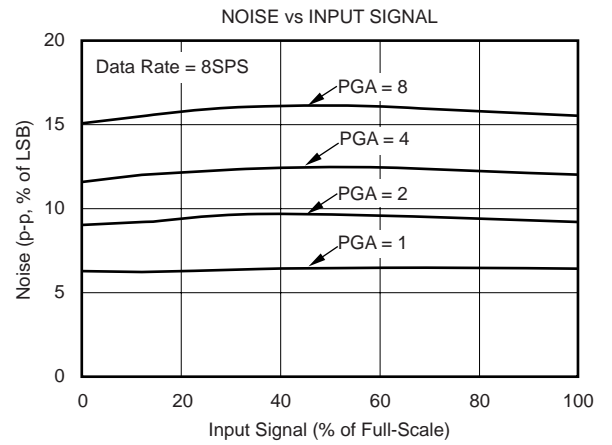
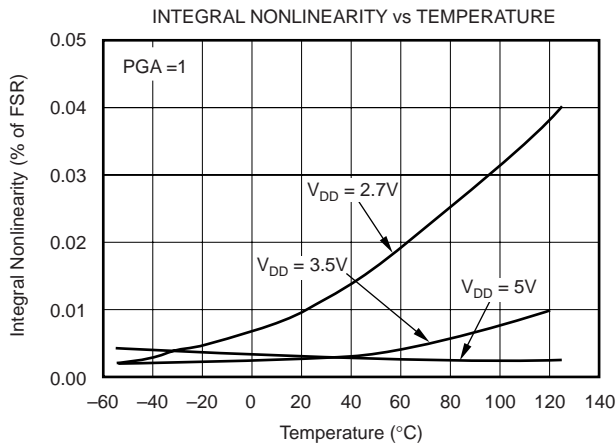
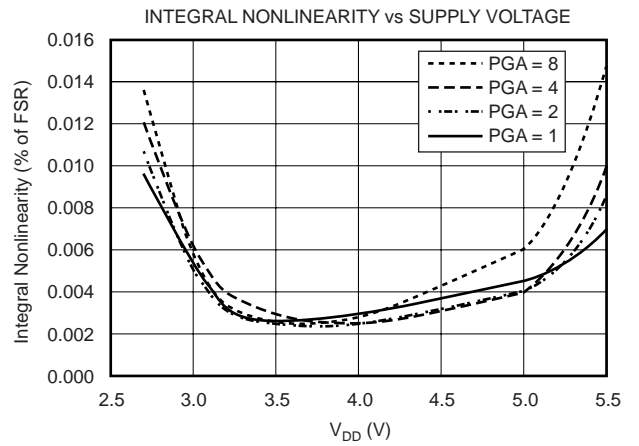
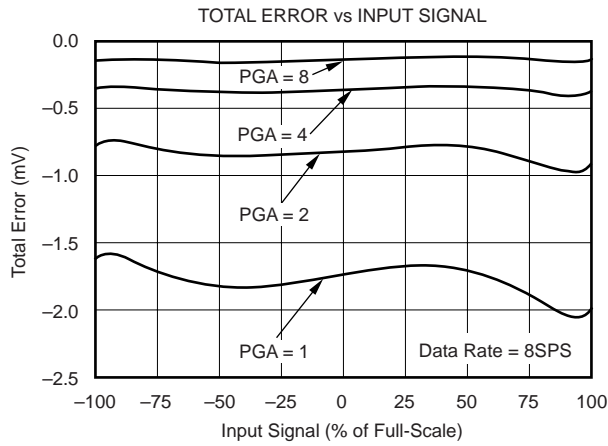

# TYPICAL CHARACTERISTICS (Cont.)

At  $T_A = 25^\circ\text{C}$  and  $V_{DD} = 5\text{V}$ , unless otherwise noted.

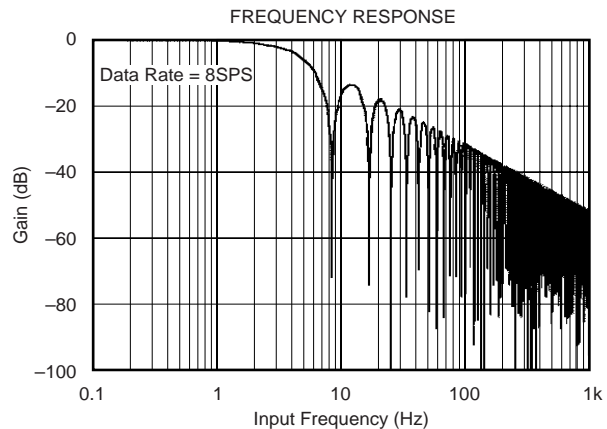
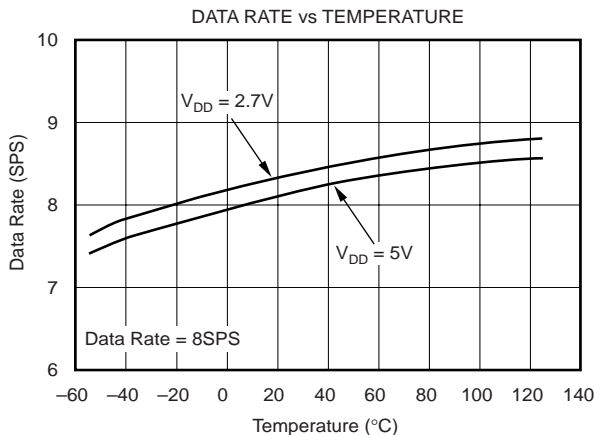

## THEORY OF OPERATION

The ADS1100 is a fully differential, 16-bit, self-calibrating, delta-sigma A/D converter. Extremely easy to design with and configure, the ADS1100 allows you to obtain precise measurements with a minimum of effort.

The ADS1100 consists of a delta-sigma A/D converter core with adjustable gain, a clock generator, and an I<sup>2</sup>C interface. Each of these blocks are described in detail in the sections that follow.

### ANALOG-TO-DIGITAL CONVERTER

The ADS1100 A/D converter core consists of a differential switched-capacitor delta-sigma modulator followed by a digital filter. The modulator measures the voltage difference between the positive and negative analog inputs and compares it to a reference voltage, which, in the ADS1100, is the power supply. The digital filter receives a high-speed bitstream from the modulator and outputs a code, which is a number proportional to the input voltage.

### OUTPUT CODE CALCULATION

The output code is a scalar value that is (except for clipping) proportional to the voltage difference between the two analog inputs. The output code is confined to a finite range of numbers; this range depends on the number of bits needed to represent the code. The number of bits needed to represent the output code for the ADS1100 depends on the data rate, as shown in Table I.

DATA RATE	NUMBER OF BITS	MINIMUM CODE	MAXIMUM CODE
8SPS	16	-32,768	32,767
16SPS	15	-16,384	16,383
32SPS	14	-8192	8191
128SPS	12	-2048	2047

TABLE I. Minimum and Maximum Codes.

For a minimum output code of Min Code, gain setting of PGA, positive and negative input voltages of  $V_{IN+}$  and  $V_{IN-}$ , and power supply of  $V_{DD}$ , the output code is given by the expression:

$$\text{Output Code} = -1 \cdot \text{Min Code} \cdot \text{PGA} \cdot \frac{(V_{IN+}) - (V_{IN-})}{V_{DD}}$$

In the previous expression, it is important to note that the *negated minimum* output code is used. The ADS1100 outputs codes in binary two's complement format, so the absolute values of the minima and maxima are not the same; the maximum n-bit code is  $2^{n-1} - 1$ , while the minimum n-bit code is  $-1 \cdot 2^{n-1}$ .

For example, the ideal expression for output codes with a data rate of 16SPS and  $\text{PGA} = 2$  is:

$$\text{Output Code} = 16384 \cdot 2 \cdot \frac{(V_{IN+}) - (V_{IN-})}{V_{DD}}$$

The ADS1100 outputs all codes right-justified and sign-extended. This makes it possible to perform averaging on the higher data rate codes using only a 16-bit accumulator.

See Table II for output codes for various input levels.

### SELF-CALIBRATION

The previous expressions for the ADS1100's output code do not account for the gain and offset errors in the modulator. To compensate for these, the ADS1100 incorporates self-calibration circuitry.

The self-calibration system operates continuously, and requires no user intervention. No adjustments can be made to the self-calibration system, and none need to be made. The self-calibration system cannot be deactivated.

The offset and gain error figures shown in the Electrical Characteristics include the effects of calibration.

DATA RATE	INPUT SIGNAL				
	NEGATIVE FULL-SCALE	-1LSB	ZERO	+1LSB	POSITIVE FULL-SCALE
8SPS	8000 <sub>H</sub>	FFFF <sub>H</sub>	0000 <sub>H</sub>	0001 <sub>H</sub>	7FFF <sub>H</sub>
16SPS	C000 <sub>H</sub>	FFFF <sub>H</sub>	0000 <sub>H</sub>	0001 <sub>H</sub>	3FFF <sub>H</sub>
32SPS	E000 <sub>H</sub>	FFFF <sub>H</sub>	0000 <sub>H</sub>	0001 <sub>H</sub>	1FFF <sub>H</sub>
128SPS	F800 <sub>H</sub>	FFFF <sub>H</sub>	0000 <sub>H</sub>	0001 <sub>H</sub>	07FF <sub>H</sub>

TABLE II. Output Codes for Different Input Signals.

## CLOCK GENERATOR

The ADS1100 features an onboard clock generator, which drives the operation of the modulator and digital filter. The Typical Characteristics show varieties in data rate over supply voltage and temperature.

It is not possible to operate the ADS1100 with an external modulator clock.

## INPUT IMPEDANCE

The ADS1100 uses a switched-capacitor input stage. To external circuitry, it looks roughly like a resistance. The resistance value depends on the capacitor values and the rate at which they are switched. The switching frequency is the same as the modulator frequency; the capacitor values depend on the PGA setting. The switching clock is generated by the onboard clock generator, so its frequency, nominally 275kHz, is dependent on supply voltage and temperature.

The common-mode and differential input impedances are different. For a gain setting of PGA, the differential input impedance is typically:

$$2.4M\Omega/PGA$$

The common-mode impedance is typically 8M $\Omega$ .

The typical value of the input impedance often cannot be neglected. Unless the input source has a low impedance, the ADS1100's input impedance may affect the measurement accuracy. For sources with high output impedance, buffering may be necessary. Bear in mind, however, that active buffers introduce noise, and also introduce offset and gain errors. All of these factors should be considered in high-accuracy applications.

Because the clock generator frequency drifts slightly with temperature, the input impedances will also drift. For many applications, this input impedance drift can be neglected, and the typical impedance values above can be used.

## ALIASING

If frequencies are input to the ADS1100 that exceed half the data rate, aliasing will occur. To prevent aliasing, the input signal must be bandlimited. Some signals are inherently bandlimited. For example, a thermocouple's output, which has a limited rate of change, may nevertheless contain noise and interference components. These can fold back into the sampling band just as any other signal can.

The ADS1100's digital filter provides some attenuation of high-frequency noise, but the filter's sinc<sup>1</sup> frequency response cannot completely replace an anti-aliasing filter; some external filtering may still be needed. For many applications, a simple RC filter will suffice.

When designing an input filter circuit, remember to take into account the interaction between the filter network and the input impedance of the ADS1100.

# USING THE ADS1100

## OPERATING MODES

The ADS1100 operates in one of two modes: continuous conversion and single conversion.

In continuous conversion mode, the ADS1100 continuously performs conversions. Once a conversion has been completed, the ADS1100 places the result in the output register, and immediately begins another conversion. When the ADS1100 is in continuous conversion mode, the ST/BSY bit in the configuration register always reads 1.

In single conversion mode, the ADS1100 waits until the ST/BSY bit in the conversion register is set to 1. When this happens, the ADS1100 powers up and performs a single conversion. After the conversion completes, the ADS1100 places the result in the output register, resets the ST/BSY bit to 0 and powers down. Writing a 1 to ST/BSY while a conversion is in progress has no effect.

When switching from continuous conversion mode to single conversion mode, the ADS1100 will complete the current conversion, reset the ST/BSY bit to 0 and power down.

## RESET AND POWER-UP

When the ADS1100 powers up, it automatically performs a reset. As part of the reset, the ADS1100 sets all of the bits in the configuration register to their default setting.

The ADS1100 responds to the I<sup>2</sup>C General Call Reset command. When the ADS1100 receives a General Call Reset, it performs an internal reset, exactly as though it had just been powered on.

## I<sup>2</sup>C INTERFACE

The ADS1100 communicates through an I<sup>2</sup>C (Inter-Integrated Circuit) interface. The I<sup>2</sup>C interface is a 2-wire open-drain interface supporting multiple devices and masters on a single bus. Devices on the I<sup>2</sup>C bus only drive the bus lines LOW, by connecting them to ground; they never drive the bus lines HIGH. Instead, the bus wires are pulled HIGH by pull-up resistors, so the bus wires are HIGH when no device is driving them LOW. This way, two devices cannot conflict; if two devices drive the bus simultaneously, there is no driver contention.







PARAMETER	FAST MODE		HIGH-SPEED MODE		UNITS
	MIN	MAX	MIN	MAX	
SCLK Operating Frequency $f_{(SCLK)}$		0.4		3.4	MHz
Bus Free Time Between STOP and START Condition $t_{(BUF)}$	600		160		ns
Hold Time After Repeated START Condition. After this period, the first clock is generated. $t_{(HDSTA)}$	600		160		ns
Repeated START Condition Setup Time $t_{(SUSTA)}$	600		160		ns
STOP Condition Setup Time $t_{(SUSTO)}$	600		160		ns
Data Hold Time $t_{(HDDAT)}$	0		0		ns
Data Setup Time $t_{(SUDAT)}$	100		10		ns
SCLK Clock LOW Period $t_{(LOW)}$	1300		160		ns
SCLK Clock HIGH Period $t_{(HIGH)}$	600		60		ns
Clock/Data Fall Time $t_F$		300		160	ns
Clock/Data Rise Time $t_R$		300		160	ns

TABLE III. Timing Diagram Definitions.

## I<sup>2</sup>C GENERAL CALL

The ADS1100 responds to General Call Reset, which is an address byte of 00<sub>H</sub> followed by a data byte of 06<sub>H</sub>. The ADS1100 acknowledges both bytes.

On receiving a General Call Reset, the ADS1100 performs a full internal reset, just as though it had been powered off and then on. If a conversion is in process, it is interrupted; the output register is set to zero, and the configuration register is set to its default setting.

The ADS1100 always acknowledges the General Call address byte of 00<sub>H</sub>, but it does not acknowledge any General Call data bytes other than 04<sub>H</sub> or 06<sub>H</sub>.

## I<sup>2</sup>C DATA RATES

The I<sup>2</sup>C bus operates in one of three speed modes: Standard, which allows a clock frequency of up to 100kHz; Fast, which allows a clock frequency of up to 400kHz; and High-speed mode (also called Hs mode), which allows a clock frequency of up to 3.4MHz. The ADS1100 is fully compatible with all three modes.

No special action needs to be taken to use the ADS1100 in Standard or Fast modes, but High-speed mode must be activated. To activate High-speed mode, send a special address byte of 00001XXX following the start condition, where the XXX bits are unique to the Hs-capable master. This byte is called the Hs master code. (Note that this is different from normal address bytes: the low bit does not indicate read/write status.) The ADS1100 will not acknowledge this byte; the I<sup>2</sup>C specification prohibits acknowledgment of the Hs master code. On receiving a master code, the ADS1100 will switch on its High-speed mode filters, and will communicate at up to 3.4MHz. The ADS1100 switches out of Hs mode with the next stop condition.

For more information on High-speed mode, consult the I<sup>2</sup>C specification.

BIT	15	14	13	12	11	10	9	8	7	6	5	4	3	2	1	0
NAME	D15	D14	D13	D12	D11	D10	D9	D8	D7	D6	D5	D4	D3	D2	D1	D0

TABLE IV. Output Register.

## REGISTERS

The ADS1100 has two registers that are accessible via its I<sup>2</sup>C port. The output register contains the result of the last conversion; the configuration register allows you to change the ADS1100's operating mode and query the status of the device.

## OUTPUT REGISTER

The 16-bit output register contains the result of the last conversion in binary two's complement format. Following reset or power-up, the output register is cleared to zero; it remains zero until the first conversion is completed. Therefore, if you read the ADS1100 just after reset or power-up, you will read zero from the output register.

The output register's format is shown in Table IV.

## CONFIGURATION REGISTER

You can use the 8-bit configuration register to control the ADS1100's operating mode, data rate, and PGA settings. The configuration register's format is shown in Table V. The default setting is 8CH.

BIT	7	6	5	4	3	2	1	0
NAME	ST/BSY	0	0	SC	DR1	DR0	PGA1	PGA0

TABLE V. Configuration Register.

### Bit 7: ST/BSY

The meaning of the ST/BSY bit depends on whether it is being written to or read from.

In single conversion mode, writing a 1 to the ST/BSY bit causes a conversion to start, and writing a 0 has no effect. In continuous conversion mode, the ADS1100 ignores the value written to ST/BSY.

When read in single conversion mode, ST/BSY indicates whether the A/D converter is busy taking a conversion. If ST/BSY is read as 1, the A/D converter is busy, and a conversion is taking place; if 0, no conversion is taking place, and the result of the last conversion is available in the output register.

In continuous mode, ST/BSY is always read as 1.

**Bits 6-5: Reserved**

Bits 6 and 5 must be set to zero.

**Bit 4: SC**

SC controls whether the ADS1100 is in continuous conversion or single conversion mode. When SC is 1, the ADS1100 is in single conversion mode; when SC is 0, the ADS1100 is in continuous conversion mode. The default setting is 0.

**Bits 3-2: DR**

Bits 3 and 2 control the ADS1100's data rate, as shown in Table VI.

DR1	DR0	DATA RATE
0	0	128SPS
0	1	32SPS
1	0	16SPS
1 <sup>(1)</sup>	1 <sup>(1)</sup>	8SPS <sup>(1)</sup>
NOTE: (1) Default Setting.		

TABLE VI. DR Bits.

**Bits 1-0: PGA**

Bits 1 and 0 control the ADS1100's gain setting, as shown in Table VII.

PGA1	PGA0	GAIN
0 <sup>(1)</sup>	0 <sup>(1)</sup>	1 <sup>(1)</sup>
0	1	2
1	0	4
1	1	8
NOTE: (1) Default Setting.		

TABLE VII. PGA Bits.

**READING FROM THE ADS1100**

You can read the output register and the contents of the configuration register from the ADS1100. To do this, address the ADS1100 for reading, and read three bytes from the device. The first two bytes are the output register's contents; the third byte is the configuration register's contents.

You do not always have to read three bytes from the ADS1100. If you want only the contents of the output register, read only two bytes.

Reading more than three bytes from the ADS1100 has no effect. All of the bytes beginning with the fourth will be FF<sub>H</sub>.

See Figure 2 for a timing diagram of an ADS1100 read operation.

**WRITING TO THE ADS1100**

You can write new contents into the configuration register (you cannot change the contents of the output register). To do this, address the ADS1100 for writing, and write one byte to it. This byte is written into the configuration register.

Writing more than one byte to the ADS1100 has no effect. The ADS1100 will ignore any bytes sent to it after the first one, and it will only acknowledge the first byte.

See Figure 3 for a timing diagram of an ADS1100 write operation.

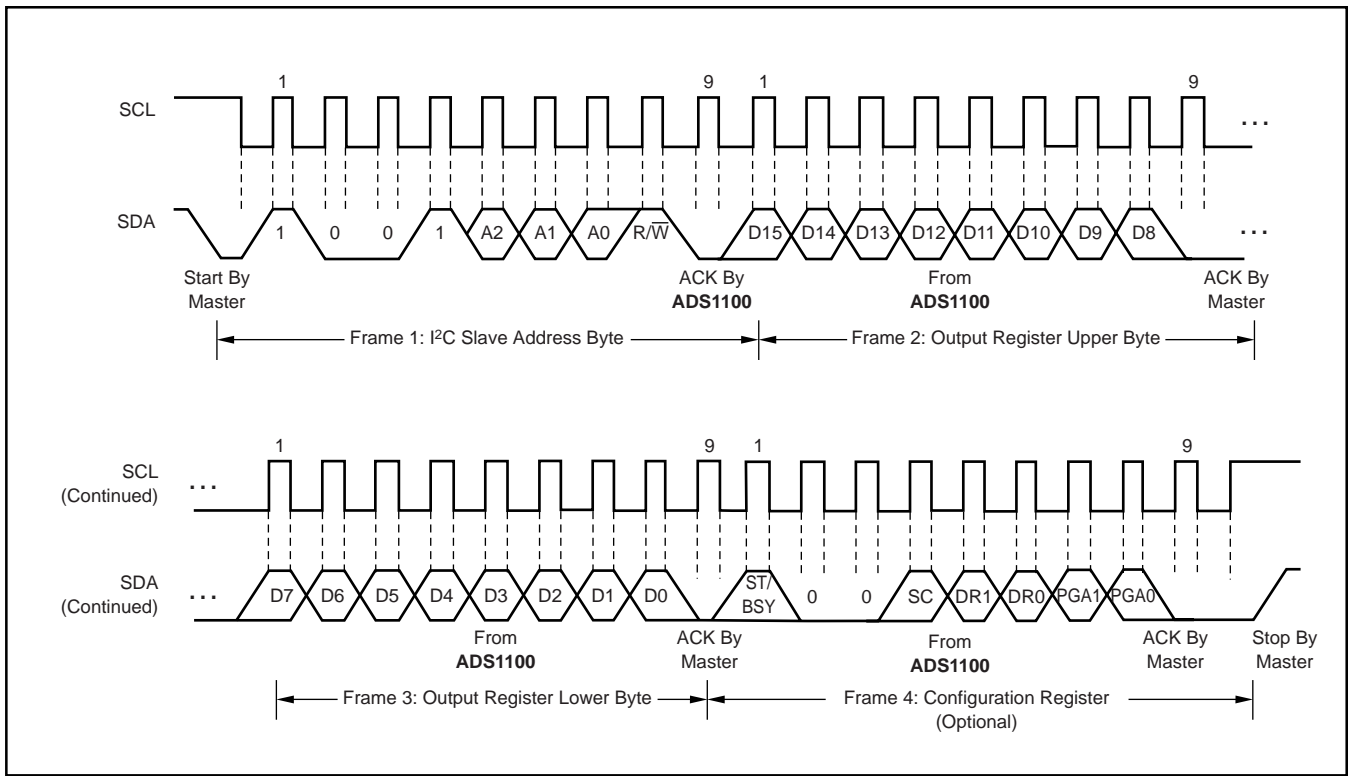

FIGURE 2. Timing Diagram for Reading From the ADS1100.

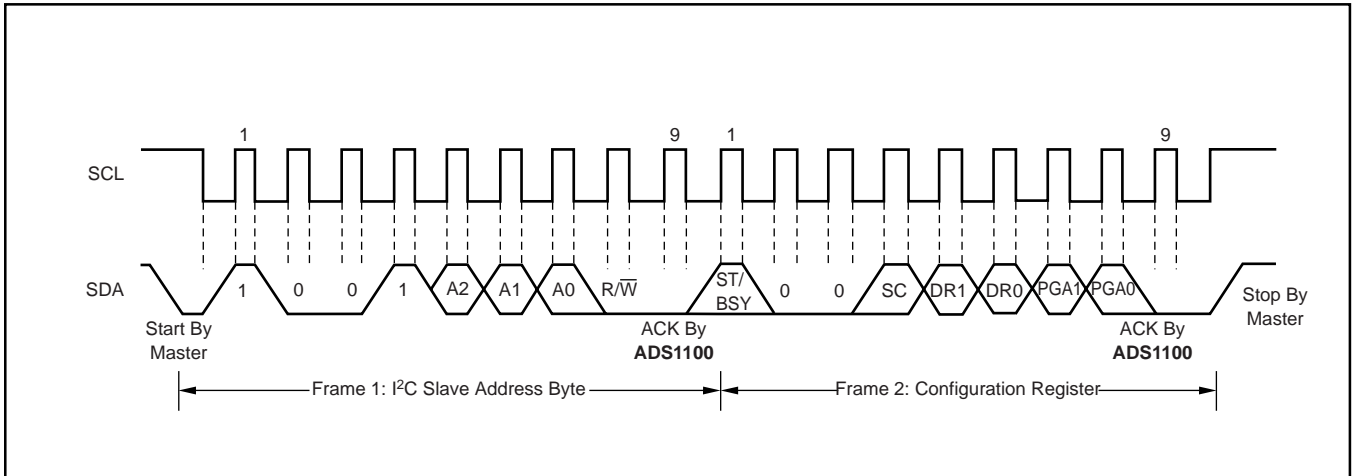

FIGURE 3. Timing Diagram for Writing to the ADS1100.

# APPLICATIONS INFORMATION

The sections that follow give example circuits and tips for using the ADS1100 in various situations.

An evaluation board, the ADS1100EVM, is available. This small, simple board connects to an RS-232 serial port on almost any PC. The supplied software simulates a digital voltmeter, and also displays raw output codes in hex and decimal. All features of the ADS1100 can be controlled from the main window. For more information, contact TI or your local TI representative, or visit the Texas Instruments website at <http://www.ti.com/>.

## BASIC CONNECTIONS

For many applications, connecting the ADS1100 is extremely simple. A basic connection diagram for the ADS1100 is shown in Figure 4.

The fully differential voltage input of the ADS1100 is ideal for connection to differential sources with moderately low source impedance, such as bridge sensors and thermistors. Although the ADS1100 can read bipolar differential signals, it cannot accept negative voltages on either input. It may be helpful to think of the ADS1100 positive voltage input as non-inverting, and of the negative input as inverting.

When the ADS1100 is converting, it draws current in short spikes. The 0.1 $\mu$ F bypass capacitor supplies the momentary bursts of extra current needed from the supply.

The ADS1100 interfaces directly to standard mode, fast mode, and high-speed mode I<sup>2</sup>C controllers. Any microcontroller's I<sup>2</sup>C peripheral, including master-only and

non-multiple-master I<sup>2</sup>C peripherals, will work with the ADS1100. The ADS1100 does not perform clock-stretching (i.e., it never pulls the clock line low), so it is not necessary to provide for this unless other devices are on the same I<sup>2</sup>C bus.

Pull-up resistors are necessary on both the SDA and SCL lines because I<sup>2</sup>C bus drivers are open-drain. The size of these resistors depends on the bus operating speed and capacitance of the bus lines. Higher-value resistors consume less power, but increase the transition times on the bus, limiting the bus speed. Lower-value resistors allow higher speed at the expense of higher power consumption. Long bus lines have higher capacitance and require smaller pull-up resistors to compensate. The resistors should not be too small; if they are, the bus drivers may not be able to pull the bus lines low.

## CONNECTING MULTIPLE DEVICES

Connecting multiple ADS1100s to a single bus is almost trivial. The ADS1100 is available in eight different versions, each of which has a different I<sup>2</sup>C address. An example showing three ADS1100s connected on a single bus is shown in Figure 5. Up to eight ADS1100s (provided their addresses are different) can be connected to a single bus.

Note that only one set of pull-up resistors is needed per bus. You might find that you need to lower the pull-up resistor values slightly to compensate for the additional bus capacitance presented by multiple devices and increased line length.

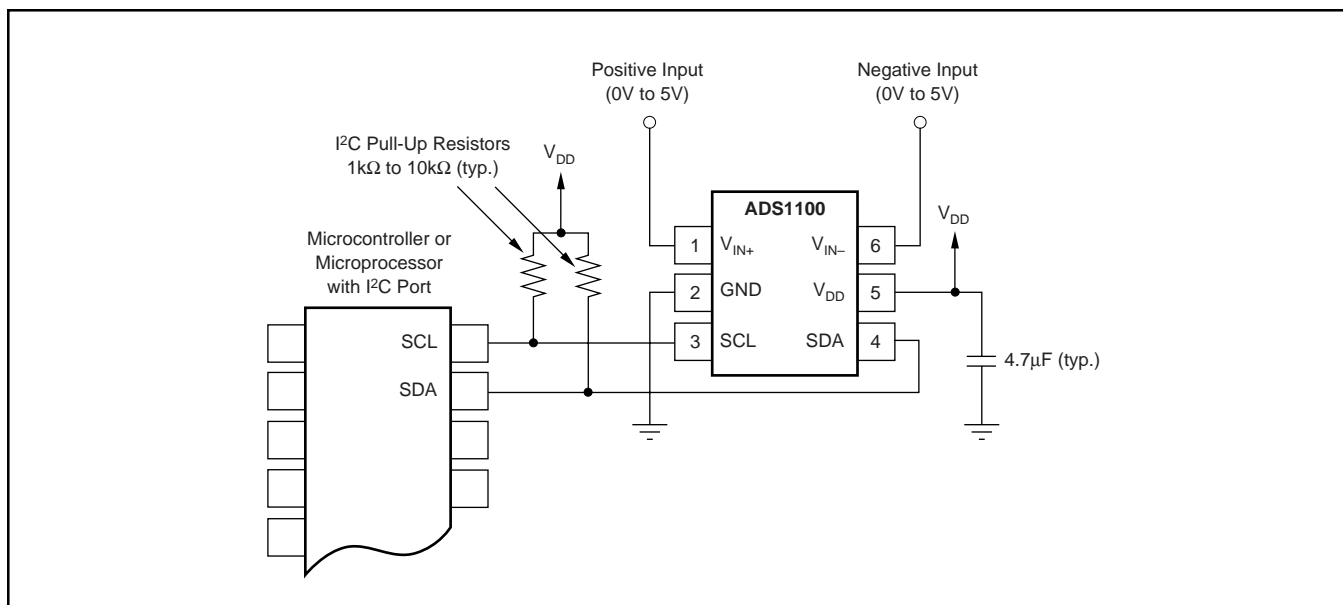

FIGURE 4. Typical Connections of the ADS1100.

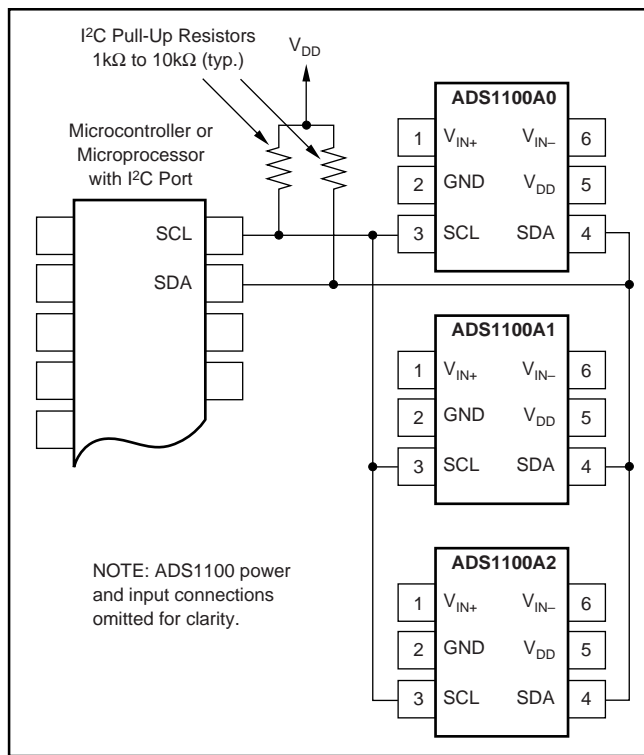

FIGURE 5. Connecting Multiple ADS1100s.

### USING GPIO PORTS FOR I<sup>2</sup>C

Most microcontrollers have programmable input/output pins that can be set in software to act as inputs or outputs. If an I<sup>2</sup>C controller is not available, the ADS1100 can be connected to GPIO pins, and the I<sup>2</sup>C bus protocol simulated, or bit-banged, in software. An example of this for a single ADS1100 is shown in Figure 6.

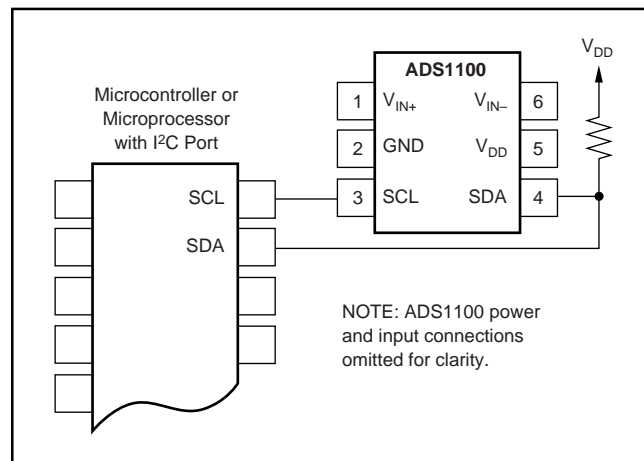

FIGURE 6. Using GPIO with a Single ADS1100.

Bit-banging I<sup>2</sup>C with GPIO pins can be done by setting the GPIO line to zero and toggling it between input and output modes to apply the proper bus states. To drive the line low, the pin is set to output a zero; to let the line go high, the pin is set to input. When the pin is set to input, the state of the pin can be read; if another device is pulling the line low, this will read as a zero in the port's input register.

Note that no pull-up resistor is shown on the SCL line. In this simple case, the resistor is not needed; the microcontroller can simply leave the line on output, and set it to one or zero as appropriate. It can do this because the ADS1100 never drives its clock line low. This technique can also be used with multiple devices, and has the advantage of lower current consumption due to the absence of a resistive pull-up.

If there are any devices on the bus that may drive their clock lines low, the above method should not be used; the SCL line should be high-Z or zero and a pull-up resistor provided as usual. Note also that this cannot be done on the SDA line in any case, because the ADS1100 does drive the SDA line low from time to time, as all I<sup>2</sup>C devices do.

Some microcontrollers have selectable strong pull-up circuits built in to their GPIO ports. In some cases, these can be switched on and used in place of an external pull-up resistor. Weak pull-ups are also provided on some microcontrollers, but usually these are too weak for I<sup>2</sup>C communication. If there is any doubt about the matter, test the circuit before committing it to production.

### SINGLE-ENDED INPUTS

Although the ADS1100 has a fully differential input, it can easily measure single-ended signals. A simple single-ended connection scheme is shown in Figure 7. The ADS1100 is configured for single-ended measurement by grounding either of its input pins, usually  $V_{IN-}$ , and applying the input signal to  $V_{IN+}$ . The single-ended signal can range from  $-0.2V$  to  $V_{DD} + 0.3V$ . The ADS1100 loses no linearity anywhere in its input range. Negative voltages cannot be applied to this circuit because the ADS1100 inputs can only accept positive voltages.

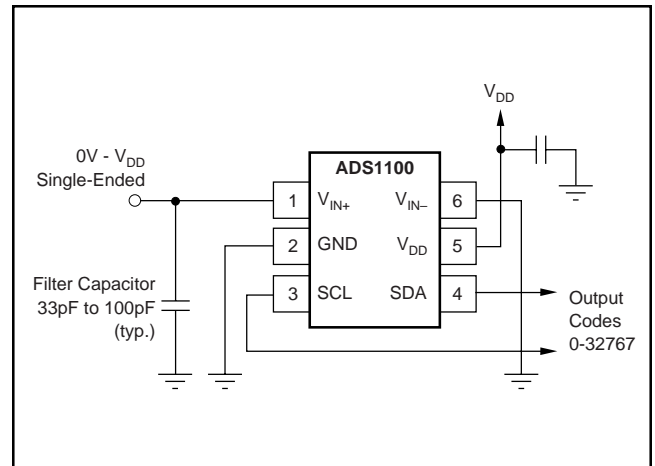

FIGURE 7. Measuring Single-Ended Inputs.

The ADS1100 input range is bipolar differential with respect to the reference, i.e.  $\pm V_{DD}$ . The single-ended circuit shown in Figure 7 covers only half the ADS1100 input scale because it does not produce differentially negative inputs; therefore, one bit of resolution is lost. The Burr-Brown DRV134 balanced line driver from Texas Instruments can be employed to regain this bit for single-ended signals.

Negative input voltages must be level-shifted. A good candidate for this function is the Texas Instruments THS4130 differential amplifier, which can output fully differential signals. This device can also help recover the lost bit noted previously for single-ended positive signals. Level shifting can also be performed using the DRV134.

### LOW-SIDE CURRENT MONITOR

Figure 8 shows a circuit for a low-side shunt-type current monitor. The circuit reads the voltage across a shunt resistor, which is sized as small as possible while still giving a readable output voltage. This voltage is amplified by an OPA335 low-drift op-amp, and the result is read by the ADS1100.

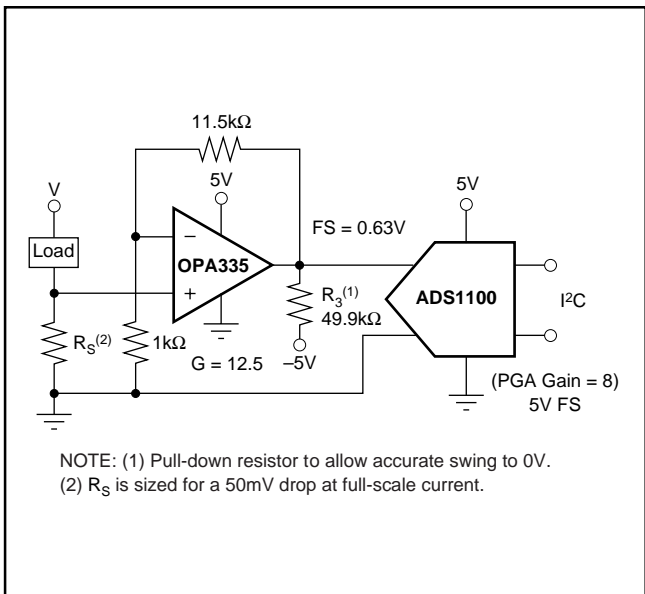

FIGURE 8. Low-Side Current Measurement.

It is suggested that the ADS1100 be operated at a gain of 8. The gain of the OPA335 can then be set lower. For a gain of 8, the op amp should be set up to give a maximum output voltage of no greater than 0.75V. If the shunt resistor is sized to provide a maximum voltage drop of 50mV at full-scale current, the full-scale input to the ADS1100 is 0.63V.

### WHEATSTONE BRIDGE SENSOR

The ADS1100 has a fully differential high-impedance input stage and internal gain circuitry, which makes it a good candidate for bridge-sensor measurement. An example is shown in Figure 9.

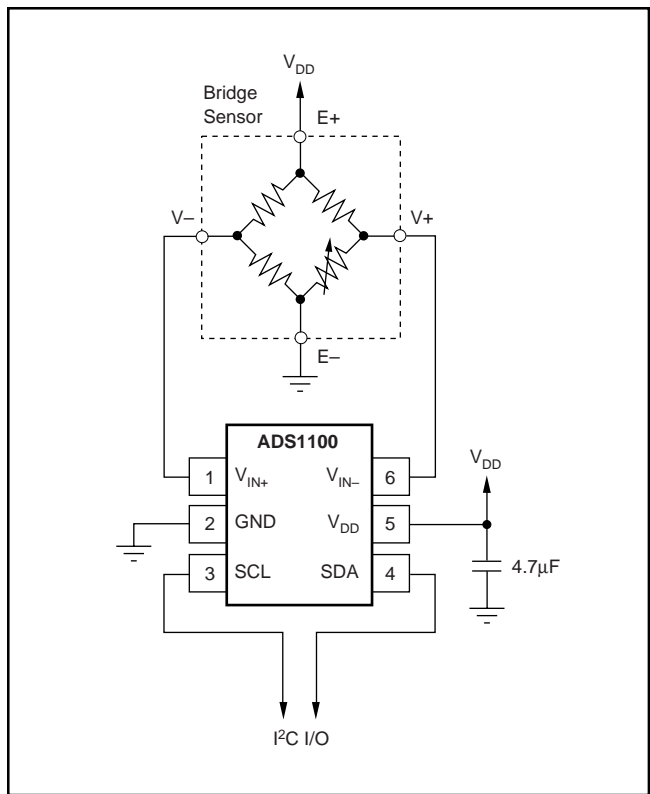

FIGURE 9. Measuring a Wheatstone Bridge Sensor.

The Wheatstone bridge sensor is connected directly to the ADS1100 without intervening instrumentation amplifiers; a single, small input capacitor provides rejection of high-frequency interference. The excitation voltage of the bridge is the power supply, which is also the ADS1100 reference voltage. The measurement is, therefore, ratiometric. In this circuit, the ADS1100 would typically be operated at a gain of 8. The input range in this case is  $\pm 0.75$  volts.

Many resistive bridge sensors, such as strain gauges, have very small full-scale output ranges. For these sensors, the measurement resolution obtainable without additional amplification can be low. For example, if the bridge sensor output is  $\pm 20\text{mV}$ , the ADS1100 outputs codes from approximately  $-873$  to  $+873$ , resulting in a best-case resolution of around 11 bits. If higher resolution is required, it is best to supply an external instrumentation amplifier to bring the signal to full scale.

### ADVICE

The ADS1100 is fabricated in a small-geometry low-voltage process. The analog inputs feature protection diodes to the supply rails. However, the current-handling ability of these diodes is limited, and the ADS1100 can be permanently damaged by analog input voltages that remain more than approximately  $300\text{mV}$  beyond the rails for extended periods. One way to protect against overvoltage is to place current-limiting resistors on the input lines. The ADS1100 analog inputs can withstand momentary currents of as large as  $10\text{mA}$ .

The previous paragraph does not apply to the I<sup>2</sup>C ports, which can both be driven to  $6\text{V}$  regardless of the supply.

If the ADS1100 is driven by an op amp with high voltage supplies, such as  $\pm 12\text{V}$ , protection should be provided, even if the op amp is configured so that it will not output out-of-range voltages. Many op amps seek to one of the supply rails immediately when power is applied, usually before the input has stabilized; this momentary spike can damage the ADS1100. Sometimes this damage is incremental and results in slow, long-term failure—which can be disastrous for permanently installed, low-maintenance systems.

If you use an op amp or other front-end circuitry with the ADS1100, be sure to take the performance characteristics of this circuitry into account. A chain is only as strong as its weakest link.

### LAYOUT TIPS

PCB layout for the ADS1100 is relatively undemanding. 16-bit performance is not difficult to achieve.

Any data converter is only as good as its reference. For the ADS1100, the reference is the power supply, and the power supply must be clean enough to achieve the desired performance. If a power-supply filter capacitor is used, it should be placed close to the  $V_{\text{DD}}$  pin, with no vias placed between the capacitor and the pin. The trace leading to the pin should be as wide as possible, even if it must be necked down at the device.



**PACKAGING INFORMATION**

Orderable Device	Status <sup>(1)</sup>	Package Type	Package Drawing	Pins	Package Qty	Eco Plan <sup>(2)</sup>	Lead/Ball Finish	MSL Peak Temp <sup>(3)</sup>
ADS1100A0IDBVR	ACTIVE	SOT-23	DBV	6	3000	Green (RoHS & no Sb/Br)	CU NIPDAU	Level-1-260C-UNLIM
ADS1100A0IDBVRG4	ACTIVE	SOT-23	DBV	6	3000	Green (RoHS & no Sb/Br)	CU NIPDAU	Level-1-260C-UNLIM
ADS1100A0IDBVT	ACTIVE	SOT-23	DBV	6	250	Green (RoHS & no Sb/Br)	CU NIPDAU	Level-1-260C-UNLIM
ADS1100A0IDBVTG4	ACTIVE	SOT-23	DBV	6	250	Green (RoHS & no Sb/Br)	CU NIPDAU	Level-1-260C-UNLIM
ADS1100A1IDBVR	ACTIVE	SOT-23	DBV	6	3000	Green (RoHS & no Sb/Br)	CU NIPDAU	Level-1-260C-UNLIM
ADS1100A1IDBVRG4	ACTIVE	SOT-23	DBV	6	3000	Green (RoHS & no Sb/Br)	CU NIPDAU	Level-1-260C-UNLIM
ADS1100A1IDBVT	ACTIVE	SOT-23	DBV	6	250	Green (RoHS & no Sb/Br)	CU NIPDAU	Level-1-260C-UNLIM
ADS1100A1IDBVTG4	ACTIVE	SOT-23	DBV	6	250	Green (RoHS & no Sb/Br)	CU NIPDAU	Level-1-260C-UNLIM
ADS1100A2IDBVR	ACTIVE	SOT-23	DBV	6	3000	Green (RoHS & no Sb/Br)	CU NIPDAU	Level-1-260C-UNLIM
ADS1100A2IDBVRG4	ACTIVE	SOT-23	DBV	6	3000	Green (RoHS & no Sb/Br)	CU NIPDAU	Level-1-260C-UNLIM
ADS1100A2IDBVT	ACTIVE	SOT-23	DBV	6	250	Green (RoHS & no Sb/Br)	CU NIPDAU	Level-1-260C-UNLIM
ADS1100A2IDBVTG4	ACTIVE	SOT-23	DBV	6	250	Green (RoHS & no Sb/Br)	CU NIPDAU	Level-1-260C-UNLIM
ADS1100A3IDBVR	ACTIVE	SOT-23	DBV	6	3000	Green (RoHS & no Sb/Br)	CU NIPDAU	Level-1-260C-UNLIM
ADS1100A3IDBVRG4	ACTIVE	SOT-23	DBV	6	3000	Green (RoHS & no Sb/Br)	CU NIPDAU	Level-1-260C-UNLIM
ADS1100A3IDBVT	ACTIVE	SOT-23	DBV	6	250	Green (RoHS & no Sb/Br)	CU NIPDAU	Level-1-260C-UNLIM
ADS1100A3IDBVTG4	ACTIVE	SOT-23	DBV	6	250	Green (RoHS & no Sb/Br)	CU NIPDAU	Level-1-260C-UNLIM
ADS1100A4IDBVR	ACTIVE	SOT-23	DBV	6	3000	Green (RoHS & no Sb/Br)	CU NIPDAU	Level-1-260C-UNLIM
ADS1100A4IDBVRG4	ACTIVE	SOT-23	DBV	6	3000	Green (RoHS & no Sb/Br)	CU NIPDAU	Level-1-260C-UNLIM
ADS1100A4IDBVT	ACTIVE	SOT-23	DBV	6	250	Green (RoHS & no Sb/Br)	CU NIPDAU	Level-1-260C-UNLIM
ADS1100A4IDBVTG4	ACTIVE	SOT-23	DBV	6	250	Green (RoHS & no Sb/Br)	CU NIPDAU	Level-1-260C-UNLIM
ADS1100A5IDBVR	ACTIVE	SOT-23	DBV	6	3000	Green (RoHS & no Sb/Br)	CU NIPDAU	Level-1-260C-UNLIM
ADS1100A5IDBVRG4	ACTIVE	SOT-23	DBV	6	3000	Green (RoHS & no Sb/Br)	CU NIPDAU	Level-1-260C-UNLIM
ADS1100A5IDBVT	ACTIVE	SOT-23	DBV	6	250	Green (RoHS & no Sb/Br)	CU NIPDAU	Level-1-260C-UNLIM
ADS1100A5IDBVTG4	ACTIVE	SOT-23	DBV	6	250	Green (RoHS & no Sb/Br)	CU NIPDAU	Level-1-260C-UNLIM
ADS1100A6IDBVR	ACTIVE	SOT-23	DBV	6	3000	Green (RoHS & no Sb/Br)	CU NIPDAU	Level-1-260C-UNLIM

Orderable Device	Status <sup>(1)</sup>	Package Type	Package Drawing	Pins	Package Qty	Eco Plan <sup>(2)</sup>	Lead/Ball Finish	MSL Peak Temp <sup>(3)</sup>
ADS1100A6IDBVRG4	ACTIVE	SOT-23	DBV	6	3000	Green (RoHS & no Sb/Br)	CU NIPDAU	Level-1-260C-UNLIM
ADS1100A6IDBVT	ACTIVE	SOT-23	DBV	6	250	Green (RoHS & no Sb/Br)	CU NIPDAU	Level-1-260C-UNLIM
ADS1100A6IDBVTG4	ACTIVE	SOT-23	DBV	6	250	Green (RoHS & no Sb/Br)	CU NIPDAU	Level-1-260C-UNLIM
ADS1100A7IDBVR	ACTIVE	SOT-23	DBV	6	3000	Green (RoHS & no Sb/Br)	CU NIPDAU	Level-1-260C-UNLIM
ADS1100A7IDBVRG4	ACTIVE	SOT-23	DBV	6	3000	Green (RoHS & no Sb/Br)	CU NIPDAU	Level-1-260C-UNLIM
ADS1100A7IDBVT	ACTIVE	SOT-23	DBV	6	250	Green (RoHS & no Sb/Br)	CU NIPDAU	Level-1-260C-UNLIM
ADS1100A7IDBVTG4	ACTIVE	SOT-23	DBV	6	250	Green (RoHS & no Sb/Br)	CU NIPDAU	Level-1-260C-UNLIM

<sup>(1)</sup> The marketing status values are defined as follows:

**ACTIVE:** Product device recommended for new designs.

**LIFEBUY:** TI has announced that the device will be discontinued, and a lifetime-buy period is in effect.

**NRND:** Not recommended for new designs. Device is in production to support existing customers, but TI does not recommend using this part in a new design.

**PREVIEW:** Device has been announced but is not in production. Samples may or may not be available.

**OBSOLETE:** TI has discontinued the production of the device.

<sup>(2)</sup> Eco Plan - The planned eco-friendly classification: Pb-Free (RoHS), Pb-Free (RoHS Exempt), or Green (RoHS & no Sb/Br) - please check <http://www.ti.com/productcontent> for the latest availability information and additional product content details.

**TBD:** The Pb-Free/Green conversion plan has not been defined.

**Pb-Free (RoHS):** TI's terms "Lead-Free" or "Pb-Free" mean semiconductor products that are compatible with the current RoHS requirements for all 6 substances, including the requirement that lead not exceed 0.1% by weight in homogeneous materials. Where designed to be soldered at high temperatures, TI Pb-Free products are suitable for use in specified lead-free processes.

**Pb-Free (RoHS Exempt):** This component has a RoHS exemption for either 1) lead-based flip-chip solder bumps used between the die and package, or 2) lead-based die adhesive used between the die and leadframe. The component is otherwise considered Pb-Free (RoHS compatible) as defined above.

**Green (RoHS & no Sb/Br):** TI defines "Green" to mean Pb-Free (RoHS compatible), and free of Bromine (Br) and Antimony (Sb) based flame retardants (Br or Sb do not exceed 0.1% by weight in homogeneous material)

<sup>(3)</sup> MSL, Peak Temp. -- The Moisture Sensitivity Level rating according to the JEDEC industry standard classifications, and peak solder temperature.

**Important Information and Disclaimer:** The information provided on this page represents TI's knowledge and belief as of the date that it is provided. TI bases its knowledge and belief on information provided by third parties, and makes no representation or warranty as to the accuracy of such information. Efforts are underway to better integrate information from third parties. TI has taken and continues to take reasonable steps to provide representative and accurate information but may not have conducted destructive testing or chemical analysis on incoming materials and chemicals. TI and TI suppliers consider certain information to be proprietary, and thus CAS numbers and other limited information may not be available for release.

In no event shall TI's liability arising out of such information exceed the total purchase price of the TI part(s) at issue in this document sold by TI to Customer on an annual basis.

**TAPE AND REEL INFORMATION**

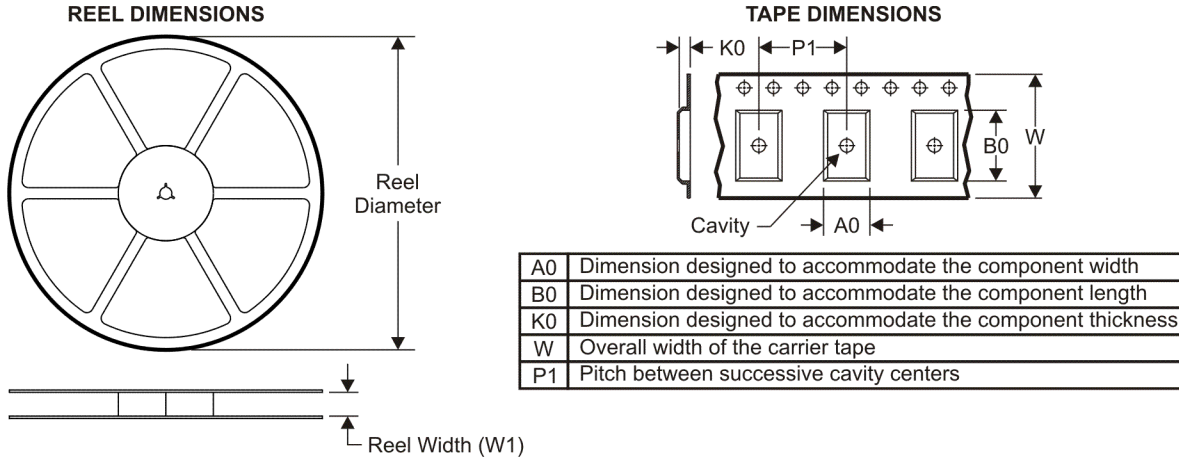

**QUADRANT ASSIGNMENTS FOR PIN 1 ORIENTATION IN TAPE**



\*All dimensions are nominal

Device	Package Type	Package Drawing	Pins	SPQ	Reel Diameter (mm)	Reel Width W1 (mm)	A0 (mm)	B0 (mm)	K0 (mm)	P1 (mm)	W (mm)	Pin1 Quadrant
ADS1100A0IDBVR	SOT-23	DBV	6	3000	180.0	8.4	3.2	3.1	1.39	4.0	8.0	Q3
ADS1100A0IDBVT	SOT-23	DBV	6	250	180.0	8.4	3.2	3.1	1.39	4.0	8.0	Q3
ADS1100A1IDBVR	SOT-23	DBV	6	3000	180.0	8.4	3.2	3.1	1.39	4.0	8.0	Q3
ADS1100A1IDBVT	SOT-23	DBV	6	250	180.0	8.4	3.2	3.1	1.39	4.0	8.0	Q3
ADS1100A2IDBVR	SOT-23	DBV	6	3000	180.0	8.4	3.2	3.1	1.39	4.0	8.0	Q3
ADS1100A2IDBVT	SOT-23	DBV	6	250	180.0	8.4	3.2	3.1	1.39	4.0	8.0	Q3
ADS1100A3IDBVR	SOT-23	DBV	6	3000	180.0	8.4	3.2	3.1	1.39	4.0	8.0	Q3
ADS1100A3IDBVT	SOT-23	DBV	6	250	180.0	8.4	3.2	3.1	1.39	4.0	8.0	Q3
ADS1100A4IDBVR	SOT-23	DBV	6	3000	180.0	8.4	3.2	3.1	1.39	4.0	8.0	Q3
ADS1100A4IDBVT	SOT-23	DBV	6	250	180.0	8.4	3.2	3.1	1.39	4.0	8.0	Q3
ADS1100A5IDBVR	SOT-23	DBV	6	3000	180.0	8.4	3.2	3.1	1.39	4.0	8.0	Q3
ADS1100A5IDBVT	SOT-23	DBV	6	250	180.0	8.4	3.2	3.1	1.39	4.0	8.0	Q3
ADS1100A6IDBVR	SOT-23	DBV	6	3000	180.0	8.4	3.2	3.1	1.39	4.0	8.0	Q3
ADS1100A6IDBVT	SOT-23	DBV	6	250	180.0	8.4	3.2	3.1	1.39	4.0	8.0	Q3
ADS1100A7IDBVR	SOT-23	DBV	6	3000	180.0	8.4	3.2	3.1	1.39	4.0	8.0	Q3
ADS1100A7IDBVT	SOT-23	DBV	6	250	180.0	8.4	3.2	3.1	1.39	4.0	8.0	Q3

**TAPE AND REEL BOX DIMENSIONS**



\*All dimensions are nominal

Device	Package Type	Package Drawing	Pins	SPQ	Length (mm)	Width (mm)	Height (mm)
ADS1100A0IDBVR	SOT-23	DBV	6	3000	184.0	184.0	50.0
ADS1100A0IDBVT	SOT-23	DBV	6	250	190.5	212.7	31.8
ADS1100A1IDBVR	SOT-23	DBV	6	3000	184.0	184.0	50.0
ADS1100A1IDBVT	SOT-23	DBV	6	250	190.5	212.7	31.8
ADS1100A2IDBVR	SOT-23	DBV	6	3000	184.0	184.0	50.0
ADS1100A2IDBVT	SOT-23	DBV	6	250	190.5	212.7	31.8
ADS1100A3IDBVR	SOT-23	DBV	6	3000	184.0	184.0	50.0
ADS1100A3IDBVT	SOT-23	DBV	6	250	190.5	212.7	31.8
ADS1100A4IDBVR	SOT-23	DBV	6	3000	184.0	184.0	50.0
ADS1100A4IDBVT	SOT-23	DBV	6	250	190.5	212.7	31.8
ADS1100A5IDBVR	SOT-23	DBV	6	3000	184.0	184.0	50.0
ADS1100A5IDBVT	SOT-23	DBV	6	250	190.5	212.7	31.8
ADS1100A6IDBVR	SOT-23	DBV	6	3000	184.0	184.0	50.0
ADS1100A6IDBVT	SOT-23	DBV	6	250	190.5	212.7	31.8
ADS1100A7IDBVR	SOT-23	DBV	6	3000	184.0	184.0	50.0
ADS1100A7IDBVT	SOT-23	DBV	6	250	190.5	212.7	31.8

DBV (R-PDSO-G6)

PLASTIC SMALL-OUTLINE PACKAGE



- NOTES:
- A. All linear dimensions are in millimeters.
  - B. This drawing is subject to change without notice.
  - C. Body dimensions do not include mold flash or protrusion. Mold flash and protrusion shall not exceed 0.15 per side.
  - D. Leads 1,2,3 may be wider than leads 4,5,6 for package orientation.
- $\triangle E$  Falls within JEDEC MO-178 Variation AB, except minimum lead width.

## IMPORTANT NOTICE

Texas Instruments Incorporated and its subsidiaries (TI) reserve the right to make corrections, modifications, enhancements, improvements, and other changes to its products and services at any time and to discontinue any product or service without notice. Customers should obtain the latest relevant information before placing orders and should verify that such information is current and complete. All products are sold subject to TI's terms and conditions of sale supplied at the time of order acknowledgment.

TI warrants performance of its hardware products to the specifications applicable at the time of sale in accordance with TI's standard warranty. Testing and other quality control techniques are used to the extent TI deems necessary to support this warranty. Except where mandated by government requirements, testing of all parameters of each product is not necessarily performed.

TI assumes no liability for applications assistance or customer product design. Customers are responsible for their products and applications using TI components. To minimize the risks associated with customer products and applications, customers should provide adequate design and operating safeguards.

TI does not warrant or represent that any license, either express or implied, is granted under any TI patent right, copyright, mask work right, or other TI intellectual property right relating to any combination, machine, or process in which TI products or services are used. Information published by TI regarding third-party products or services does not constitute a license from TI to use such products or services or a warranty or endorsement thereof. Use of such information may require a license from a third party under the patents or other intellectual property of the third party, or a license from TI under the patents or other intellectual property of TI.

Reproduction of TI information in TI data books or data sheets is permissible only if reproduction is without alteration and is accompanied by all associated warranties, conditions, limitations, and notices. Reproduction of this information with alteration is an unfair and deceptive business practice. TI is not responsible or liable for such altered documentation. Information of third parties may be subject to additional restrictions.

Resale of TI products or services with statements different from or beyond the parameters stated by TI for that product or service voids all express and any implied warranties for the associated TI product or service and is an unfair and deceptive business practice. TI is not responsible or liable for any such statements.

TI products are not authorized for use in safety-critical applications (such as life support) where a failure of the TI product would reasonably be expected to cause severe personal injury or death, unless officers of the parties have executed an agreement specifically governing such use. Buyers represent that they have all necessary expertise in the safety and regulatory ramifications of their applications, and acknowledge and agree that they are solely responsible for all legal, regulatory and safety-related requirements concerning their products and any use of TI products in such safety-critical applications, notwithstanding any applications-related information or support that may be provided by TI. Further, Buyers must fully indemnify TI and its representatives against any damages arising out of the use of TI products in such safety-critical applications.

TI products are neither designed nor intended for use in military/aerospace applications or environments unless the TI products are specifically designated by TI as military-grade or "enhanced plastic." Only products designated by TI as military-grade meet military specifications. Buyers acknowledge and agree that any such use of TI products which TI has not designated as military-grade is solely at the Buyer's risk, and that they are solely responsible for compliance with all legal and regulatory requirements in connection with such use.

TI products are neither designed nor intended for use in automotive applications or environments unless the specific TI products are designated by TI as compliant with ISO/TS 16949 requirements. Buyers acknowledge and agree that, if they use any non-designated products in automotive applications, TI will not be responsible for any failure to meet such requirements.

Following are URLs where you can obtain information on other Texas Instruments products and application solutions:

### Products

Amplifiers	<a href="http://amplifier.ti.com">amplifier.ti.com</a>
Data Converters	<a href="http://dataconverter.ti.com">dataconverter.ti.com</a>
DSP	<a href="http://dsp.ti.com">dsp.ti.com</a>
Clocks and Timers	<a href="http://www.ti.com/clocks">www.ti.com/clocks</a>
Interface	<a href="http://interface.ti.com">interface.ti.com</a>
Logic	<a href="http://logic.ti.com">logic.ti.com</a>
Power Mgmt	<a href="http://power.ti.com">power.ti.com</a>
Microcontrollers	<a href="http://microcontroller.ti.com">microcontroller.ti.com</a>
RFID	<a href="http://www.ti-rfid.com">www.ti-rfid.com</a>
RF/IF and ZigBee® Solutions	<a href="http://www.ti.com/lprf">www.ti.com/lprf</a>

### Applications

Audio	<a href="http://www.ti.com/audio">www.ti.com/audio</a>
Automotive	<a href="http://www.ti.com/automotive">www.ti.com/automotive</a>
Broadband	<a href="http://www.ti.com/broadband">www.ti.com/broadband</a>
Digital Control	<a href="http://www.ti.com/digitalcontrol">www.ti.com/digitalcontrol</a>
Medical	<a href="http://www.ti.com/medical">www.ti.com/medical</a>
Military	<a href="http://www.ti.com/military">www.ti.com/military</a>
Optical Networking	<a href="http://www.ti.com/opticalnetwork">www.ti.com/opticalnetwork</a>
Security	<a href="http://www.ti.com/security">www.ti.com/security</a>
Telephony	<a href="http://www.ti.com/telephony">www.ti.com/telephony</a>
Video & Imaging	<a href="http://www.ti.com/video">www.ti.com/video</a>
Wireless	<a href="http://www.ti.com/wireless">www.ti.com/wireless</a>

Mailing Address: Texas Instruments, Post Office Box 655303, Dallas, Texas 75265  
Copyright © 2008, Texas Instruments Incorporated